

GUNS & HISTORY

AMERICAN CIVIL WAR

6-POUNDER

JAMES

WOOD CARRIAGE ASSEMBLY INSTRUCTIONS

AXLE (See Drawing #1)

From WP 3332 5/16" x 5/16" x 3" cut piece 2-3/4" long. Sand two sides until piece fits snugly into notch on underside of trails. Find center at each end by marking two diagonals corner to corner and carefully drill a 3/16" diameter hole 7/16" deep in each end.

Glue 3/16" diameter by 1-5/16" long brass rod in each end leaving 7/8" protruding.

Cut two strips of gasket material 1/8" wide and glue around ends of wooden axle.

- Optional. Drill a small blind hole in the center of each face. Cut nails to 1/8" long, retaining the heads and glue into holes.

TRAILS (See Drawing #2)

Three laser cut pieces will make up the trails. Left and right trails are 3/16" thick and center trail is 1/8" thick.

Before any assembly, take the elevator screw and housing, file the screw head square to fit notch on the top of the center trail. Next — mark the top of the center trail for the hold-down pins of the elevator screw housing. 1/16" diameter holes will be drilled 1/8" deep after the trails have been laminated together.

Mark holes for rope cleats in center trail. File and sand the edges of the three trail pieces to remove laser burns where they will be visible after completion. Final sanding will be done after lamination. The left and right trails should be filed and sanded to the dimensions shown in the top view of the assembly, tapering so they are flush in the tow bar and skid. Carefully file the left and right trail ends so that the tow bar and skid can slide on after the trails are assembled.

Clamp left cheek to left trail using the axle for alignment making sure bottom edges are flush. Mark the holes in cheek onto the trail, disassemble and drill a blind hole in each location into trail.

Note. Only the two front holes in left trail.

Repeat procedure with right cheek and trail for three holes. Dry fit the various castings that will be attached to the trails making sure the holes are the correct size.

Glue the three trail pieces together using the axle to maintain alignment.

Sand top, bottom and front until all surfaces are level with each other.

Drill the holes for the elevating screw and housing pins and the rope cleats.

Cut two pieces 9/32" x 9/32" square from gasket material and glue one on each side of trails as shown. Drill small blind holes in four corners and glue in four cut off brass nails. Paint and glue bottom trail angle into position as shown.

CHEEKS (See Drawing #1)

File and sand the back edge of each cheek so it is half round. In outside faces, locate and drill blind holes for spike rings, cap chain posts and linstock. Check castings and file as necessary to fit.

Lightly sand faces to remove laser burn marks. Edges can be sanded to remove loose material. It is not necessary to remove all black marks as edges will be covered.

Take 1/8" wide strips of gasket and, starting in front of axle notch, carefully glue to the edge of each cheek. At the trunnion notch press material into place with the 1/4" diameter trunnion until the glue has set. Continue to the back then cut and sand to the shape of the radius.

Glue another piece from the axle notch to the back on the bottom edge of the cheek and again sand to match the radius.

Note: Be sure to leave space on each side of axle notch to allow for side shackle installation.

Now drill blind holes for trunnion cap pins (two per cheek) and drift rods (five per cheek). Drill blind hole for piton in bottom of each cheek as shown.

Glue pieces of 16 gage brass wire into holes for cap chain posts, trunnion cap pins and drift rods. Allow approximately 3/32" to protrude at cap chain posts and trunnion cap pins and 1/16" at drift rods. Glue square washers from gasket material on drift rods.

Glue three #6 washers to inside face of each cheek after painting them black. Center washers on drift pin holes.

Optional. On front face of each cheek drill six blind holes and insert cut off brass nails leaving heads exposed.

WHEELS (See Assembly Drawing)

Hubs should be painted before assembling the wheels. Spray hubs with aluminum primer then apply finish color of your choice.

Assemble both wheels in accordance with drawing instructions.

ASSEMBLY

Glue five drift pins of 16 ga. Brass wire into trails (2 left and 3 right). They should be long enough to extend approximately 1/16" beyond the outside face of the cheeks when assembled to the trails and axle. Glue a short piece of 16 gage brass wire in the back hole on the left trail extending 3/32" from the face of the trail.

Center axle in notch on trail assembly and glue.

Finish all woodwork using satin varnish or finish of your choice.

Slide each cheek onto the drift pins and glue into place.

Glue square washers from gasket material on drift pins protruding through cheeks.

Glue bottom trail angle into position as shown.

Slide one #8 washer on each axle and glue.

Install wheels on axles and glue cap and fid on each axle.

Follow other directions enclosed to install all other castings, etc. in their respective positions.

WOOD CARRIAGE #1

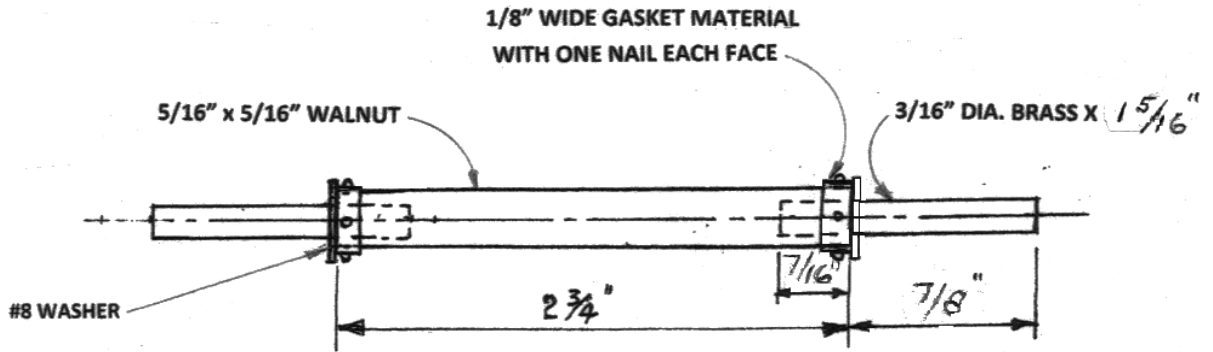

AXLE

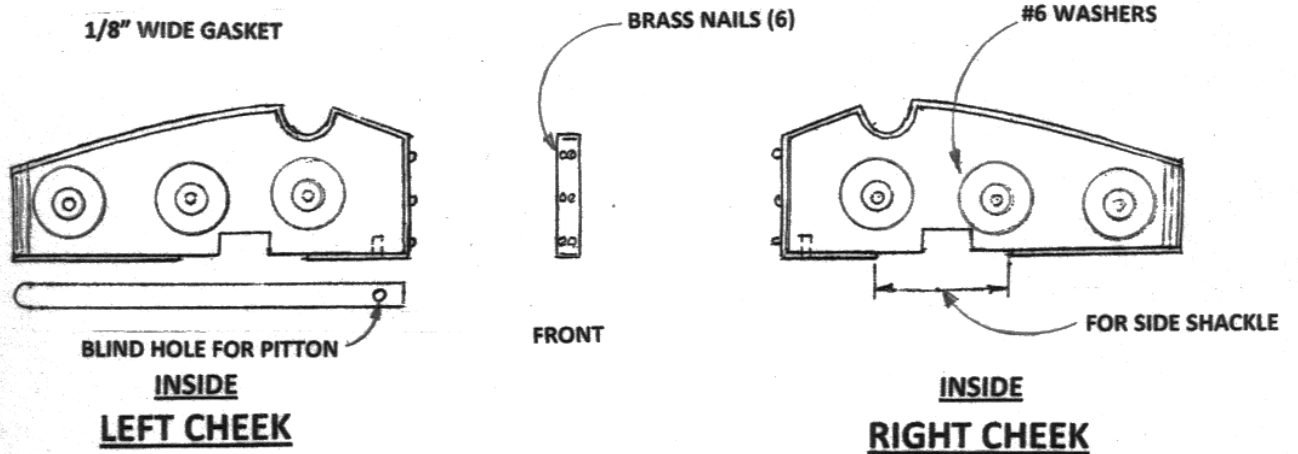
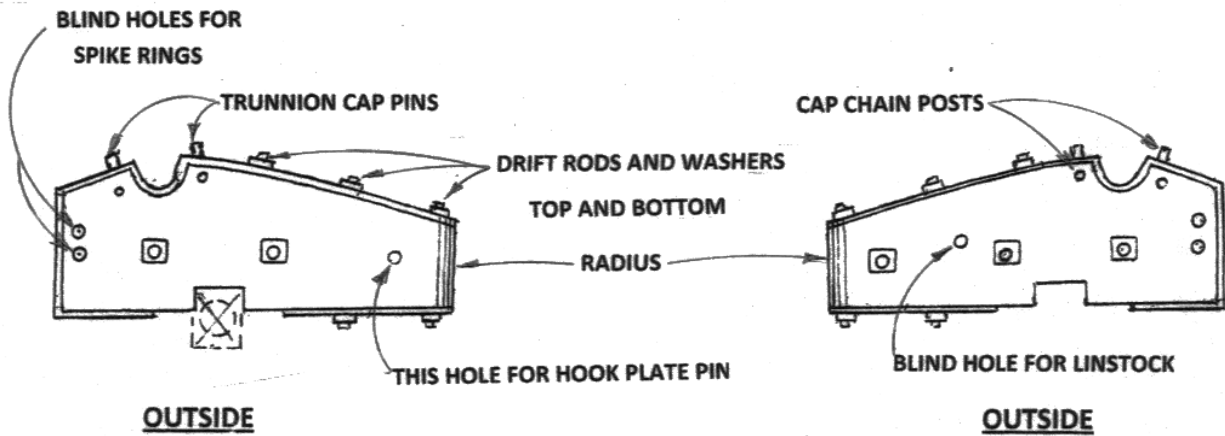

WOOD CARRIAGE #2

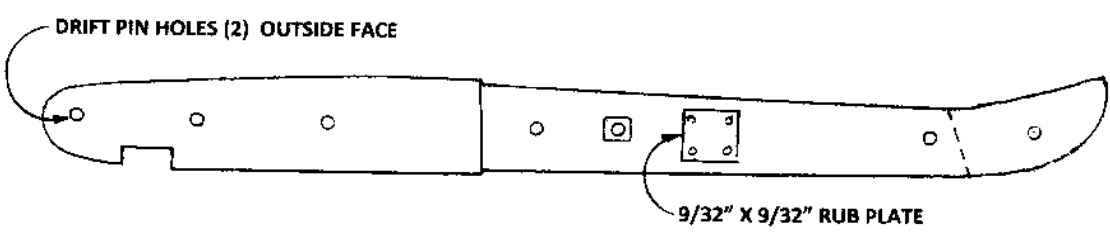
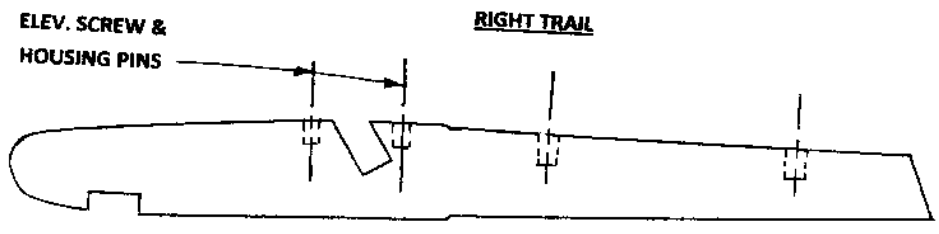
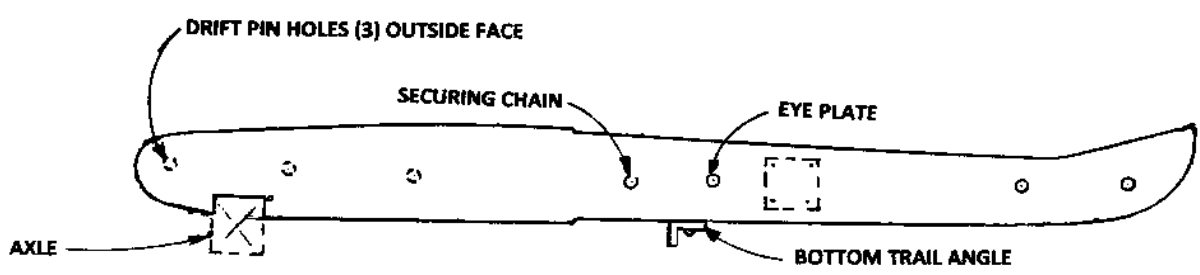
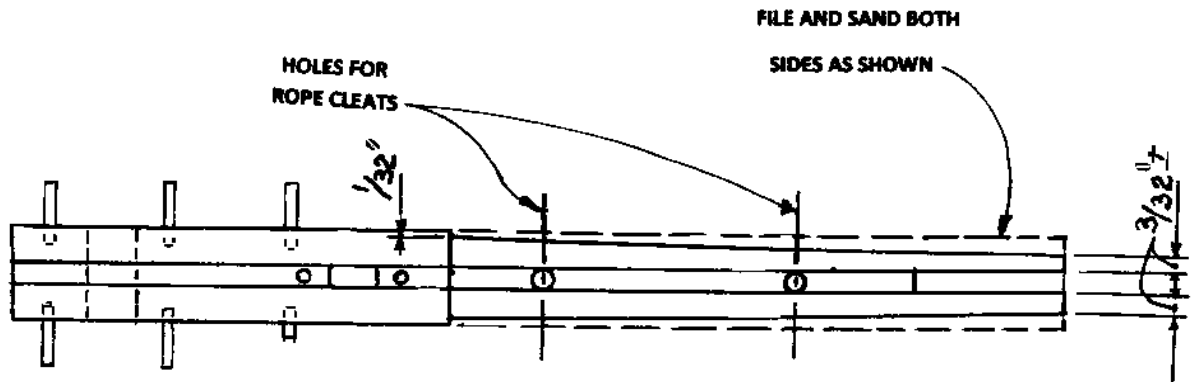

TRAILS