

PAPER ASSEMBLY PATTERN SUPPLIED:

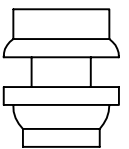
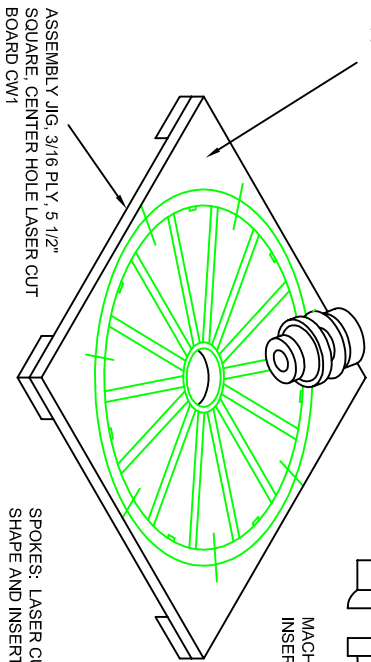

OUTBOARD END  
NOTE THAT OUTBOARD END GOES DOWN

MACHINED METAL HUB INSERT IN CENTER HOLE

SPOKES: LASER CUT, 3/32 BASSWOOD, BOARD CW2  
SHAPE AND INSERT IN HUB, BUTT TO WHEEL

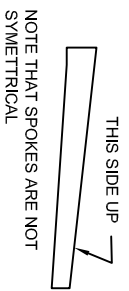

COVER PATTERN WITH WAXED PAPER DRILL AND SECURE WHEEL TO JIG WITH SMALL NAILS

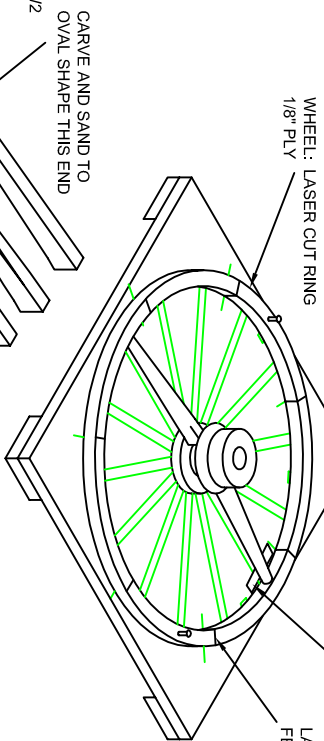

SCRAP 1/64 PLY SPACER UNDER SPOKE END

LASER ENGRAVED FELLE JOINT MARKS

CARVE AND SAND TO OVAL SHAPE THIS END

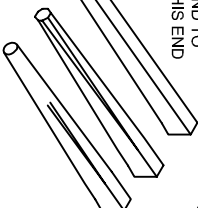

IRON TIRE, CUT FROM GASKET MATERIAL SUPPLIED

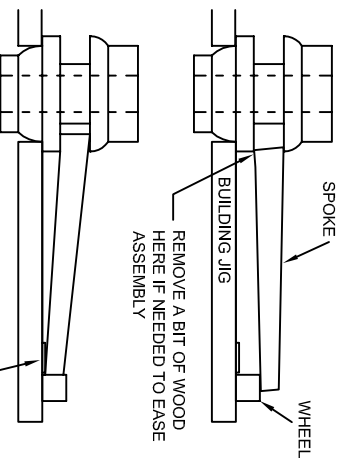

1/64 SPACER

1/32 GASKET MATERIAL, SIMULATED IRON TIRE, CUT FROM MATERIAL SUPPLIED

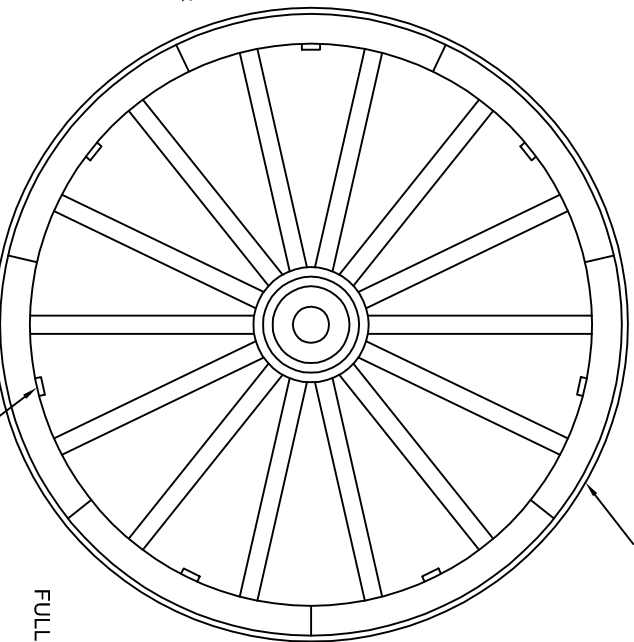
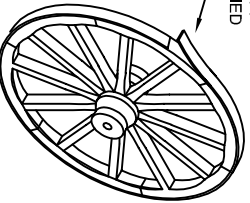

FULL SIZE

1/32 X 3/32 SQUARE

THE IRON TIRES WERE SECURED TO THE WHEEL WITH FLAT HEAD BOLTS AND SQUARE NUTS ON THE INSIDE OF THE WHEEL. CUT SIMULATED NUTS FROM STRIP STOCK SUPPLIED

FOR ADDED DETAIL, LIGHTLY CUT FELLE JOINT MARKS AROUND WHEEL WITH RAZOR SAW OR KNIFE  
CUT OUT CENTER HOLE IN PATTERN. TACK GLUE TO JIG. COVER PATTERN WITH WAXED PAPER. DRILL AND FASTEN WHEEL TO PATTERN WITH SMALL NAILS PROVIDED.

CARVE AND SAND SPOKES AS SHOWN. FIT AND INSERT EACH SPOKE IN HUB, THEN BUTT TO WHEEL  
GLUE IN PLACE USING A GAP FILLER CA GLUE THE 1/64 SPACERS WILL CENTER THE SPOKE ON THE WHEEL

WHEN ALL SPOKES ARE IN PLACE, APPLY THIN CA ALL AROUND HUB AND TO EACH SPOKE END AT WHEEL, TURN WHEEL OVER AND REPEAT

FILL NAIL HOLES AND FINISH WHEEL. THEN APPLY 1/8 WIDE STRIP IRON TIRE. CUT FROM GASKET MATERIAL SUPPLIED

### PARTS LIST

- LASER CUT BOARD CW1, 1/8 PLY
- LASER CUT BOARD CW2, 3/32 BASSWOOD
- MACHINED HUBS (2)
- BLACK GASKET MATERIAL 1/2" X 11"
- STRIP WOOD 1/32" X 3/32" X 6"
- 1/64" PLY, 3/16" X 3"
- BRASS NAILS, 1/2", (4)
- PATTERN SHEET (1)

# GUNS OF HISTORY

CANNON CARRIAGE WHEEL CONSTRUCTION

BOB CRANE 2010

© MODEL EXPO, INC.